



Micromill

CNC MILLING MACHINE

Microturn

CNC LATHE



Micromill and Microturn

CNC MILLING MACHINE AND CNC LATHE

A compact 3 axis CNC milling machine and 2 axis CNC lathe, both with totally enclosed interlocking guards - the ideal introduction to small part CNC manufacture. Variable spindle speeds and feedrates make the MicroMill and MicroTurn ideal for cutting resistant materials such as wax, plastic, acrylic, aluminum and free cutting alloys.

THE MICROMILL COMES AS STANDARD WITH:

- VR CNC Milling Operating Software (PC not included).
- Installation and Instruction Manuals.
- Maintenance Tools.
- Clamping Kit.
- 1/4" Dia Milling Collet.
- 5/16" Dia Drawbar.
- 3/16" Slot Drill 1/4" Shank.
- Set of Metric Allen Keys.

THE MICROTURN COMES AS STANDARD WITH:

- VR CNC Turning Operating Software (PC not included).
- Installation and Instruction Manuals.
- Maintenance Tools.
- 1 1/2" Standard Toolpost.
- Tailstock.
- 3" Dia Spindle Faceplate.
- No. 1 Morse Taper, Spindle Centre.
- No. 0 Morse Taper, Tailstock Centre.
- 2 1/2" Dia 3 Jaw Chuck & 2 Tommy Bars.
- 1/4" Braised Carbide Tip Cutting Tool, Right Handed.

OPTIONAL EXTRAS INCLUDE:

Quickchange toolpost and thread cutting package.

SYSTEM REQUIREMENTS

For MicroMill please refer to page 13.
For MicroTurn please refer to page 19.



MECHANICAL DETAILS	MICROMILL	MICROTURN
Machine Length (A)	685mm	685mm
Machine Depth (B)	654mm	654mm
Machine Height (C)	688mm	688mm
Machine Weight	50kg	57kg
Table Size	70x330mm	n/a
Swing Over Bed	n/a	90mm 150mm opt.
Travel X Axis	228mm	50mm
Travel Y Axis	130mm	n/a
Travel Z Axis	160mm	126mm
Table to Spindle	182mm	n/a
Max. Spindle Speed	2800rpm	2800rpm
Max. Feed Rate	750mm/min	600mm/min
Max. 3D Profiling	600mm/min	n/a
Mains Supply Requirements* [* Alternative supplies available on request]	Single Phase	Single Phase
Spindle Motor	0.37kW	0.37kW
Axes Motors	Stepper	Stepper
Volts	230Volts	230Volts
Amps	8 Amp	8 Amp
Hz	50 Hz	50 Hz
Electrical Connection	13A Socket	13A Socket

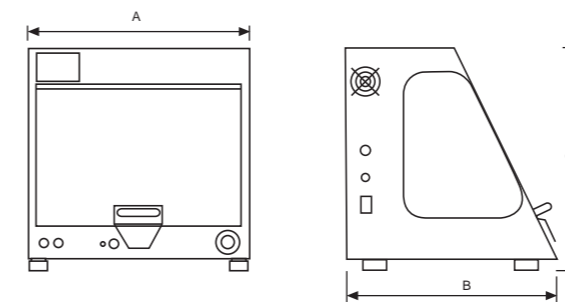

Machine Dimensions.



Benches on this page are no longer available and are shown for illustration purposes only.



To get you up and running, Denford also offer a range of CNC Routers, Lasers, Milling Machines and Lathes, together with tooling packages, workholding kits and courseware.

Total Commitment to Manufacturing Technology in Education and Training Worldwide. ISO9001 compliant.

Denford reserves the right to alter machines and software specifications without prior notice. All Denford products are subject to copyright. All brands and products are trademarks or registered trademarks of their respective companies.



Get help, advice and share designs online
www.denfordata.com/bb



CALL NOW T: +44(0)1484 728000

F: +44(0)1484 728100 Email: info@denford.co.uk
Denford Limited, Birds Royd, Brighouse, West Yorkshire HD6 1NB, England