

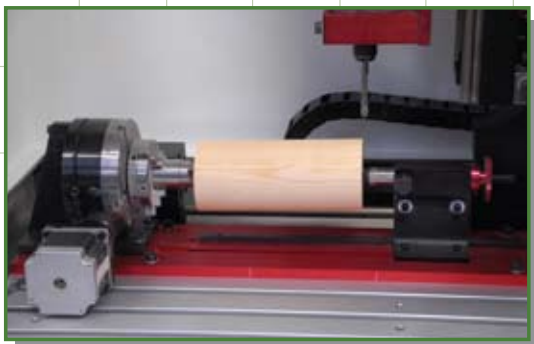

Compact 1000 PRO

COMPACT METAL CUTTING 3 AXIS CNC ROUTER



4th Axis Programmable Rotary Fixture
See Router Accessories on page 37.



Shown with optional universal bench and computer support extension (PC not included)

Compact 1000 PRO

COMPACT METAL CUTTING 3 AXIS CNC ROUTER

A compact 3 axis CNC Router with totally enclosed interlocking guard, suitable for all levels of education and training. The Compact 1000 Pro is ideal for cutting a range of resistant materials such as hard and soft wood, plastic, modelling foam, acrylic and prototyping materials, as well as non-ferrous metals.

THE COMPACT 1000 PRO COMES AS STANDARD WITH:

- VR CNC Milling Operating Software (PC not included).
- Aluminium T Slot Table.
- Outlet for Dust Extraction System.
- Workholding Clamps.
- Installation and Instruction Manuals.
- USB Connection.

OPTIONAL EQUIPMENT INCLUDES:

- Vacuum Pads, F1 in Schools Car Manufacturing Fixture, 4th Axis Programmable Rotary Fixture, 3D Scanning Attachment, Universal Machine Bench and Dust Extraction Unit.

SYSTEM REQUIREMENTS

Please refer to page 13.

RECOMMENDED SOFTWARE PROGRAMS

All software necessary to control the Compact 1000 Pro is included. Also included is a seat of QuickCAM 2D Design - an easy to use 2D CAD package.

- For 2D Designs - will link to packages able to export 2D dxf files such as QuickCAM 2D Design, TechSoft Design Tools - 2D Design, CorelDraw etc.
- For 3D Designs - will link to packages able to export STL files such as Pro/DESKTOP, ArtCAM and Autodesk Inventor SolidWorks etc. when used in conjunction with QuickCAM Pro.

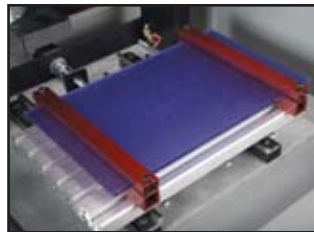
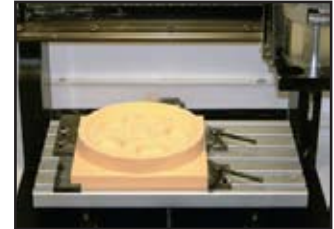
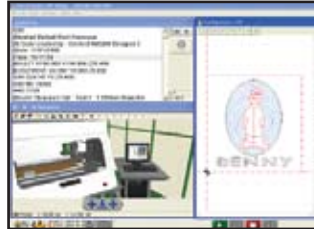

MECHANICAL DETAILS	COMPACT 1000 PRO
Machine Length (A)	875mm
Machine Depth (B)	750mm
Machine Height (C)	675mm
Length with Optional Base (D)	1600mm
Height with Optional Base (E)	1440mm
Machine Weight	116kg
Machine Weight with Opt. Base	230kg
Table Size	400 x 240mm
Travel X Axis	400mm
Travel Y Axis	240mm
Travel Z Axis	110mm
Beam Clearance	140mm
Max. Spindle Speed	24000rpm
Non-Ferrous Metal Cutting	Yes
Spindle Speed Control	Yes
Spindle Speed Override	Yes
Max. Feed Rate	5000mm/min
Max. 3D Profiling	4500mm/min
Mains Supply Requirements* [* Alternative supplies available on request]	Single Phase
Spindle Motor	1.0kW
Axes Motors	Stepper
Volts	230 Volts
Amps	8 Amps
Hz	50 Hz
Electric Connection	13A Socket

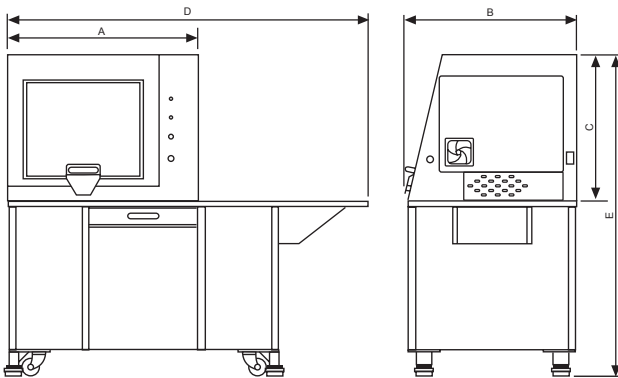

Machine Dimensions.



Get help, advice and share designs online
www.denfordata.com/bb

To get you up and running, Denford also offer a range of CNC Routers, Lasers, Milling Machines and Lathes, together with tooling packages, workholding kits and courseware.

Total Commitment to Manufacturing Technology in Education and Training Worldwide. ISO9001 compliant.

Denford reserves the right to alter machines and software specifications without prior notice. All Denford products are subject to copyright. All brands and products are trademarks or registered trademarks of their respective companies.